

FALL TYPE METAL DETECTOR

NMD-530 Series

QUICKER[®]



Certified by CE mark 

QUICKER[®]

NMD530 Series (QUICKER) fall type metal detector is designed to be installed at the beginning of the production line to inspect materials in bulk powder or granule form or at any point where inspection of free falling products is necessary.

Providing unrivalled levels of detection sensitivity through an array of innovative features and advantages, NMD530 Series (QUICKER) fall type metal detector is ideal for minimized height allowing them to be installed in the often restricted space between a weigher and a bag maker.

- For Inspecting Powders and Fine-Grained Bulk Materials
- Metal Separation Using a Reject Diverter System
- Minimal Installation Space
- Unrivalled Detection Sensitivity
- Full Color Touch Screen (7 inch TFT LCD)
- Digital Signal Processing (32-Bit Microprocessor)
- Auto-Setting Function of the Inspection Items
- Powerful Durability (IP66)
- Smart Self-Diagnosis
- USB Port for Data Management
- RS232C & 485 data link ports
- Security System (3-Level Password)
- Metal Detecting History Management
- Easy Software upgrade
- Variable Languages Option

 Total Inspection Systems & solution
NOW SYSTEMS CO., LTD.



FALL TYPE METAL DETECTOR

NMD-530 Series

QUICKER[®]



For Inspecting Powders and Fine-Grained Bulk Materials

- Offering the highest levels of sensitivity for inspecting various types of powders and fine-grained bulk materials
- Ideal for inspecting product while inflight between the weigher and bagger

Metal Separation Using a Reject Diverter System

- Flap type reject diverter system is suitable for various types of powders and fine-grained bulk materials

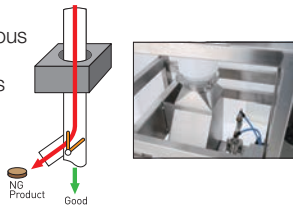

Minimal Installation Space

- Installation in restricted spaces in vertical packaging application between the weigher and bagger.

Unrivalled Detection Sensitivity

- The use of high frequency technology combined with enhanced filtering techniques delivers the highest levels of sensitivity across all metal types.

Full Color Touch Screen (7 inch TFT LCD)

- An intuitive and convenient full color touch screen, containing regional languages and user manual

Connectivity to External Devices

- Backing up inspection history and etc., by using a USB removable disk and reviewing the data on a PC.
- Monitoring real-time operating status for multiple metal detectors through the connective access to LAN.
- Interlocking the machine to various typed external devices through RS232C & 485 port.

Auto-Setting Function of the Inspection Items

- Auto-setting the machine for a testing product with the most suitable values even for beginners

Setting Function of a Variety of Items for Convenient Operation

- Up to 100 kinds of products are registered with each different setting value for convenient operation.

Manageable Metal Detecting History

- Detection history by various classifications and periods (in a daily / weekly / monthly / period-specified way)
- Data on detection history accessibility by LCD screen, USB disk and Printer (Optional).

Easy Software Upgrade

- Easy software upgradability by USB and touch screen whenever the latest version is available

Password Setup Function

- Setting up each three different passwords depending on each status (a user, an administrator and an engineer)

External Output Printer Setup Function

- Additional option for installing an external output printer for detection history

Outputs

- Relay (5A) / 1A1B 2EA, DC24V SOL, AC220V 0.2A

Power Supply

- Single Phase (110 to 220V) & Three Phase (220 to 380V and etc.,)
- Free Cycle (50/60Hz)
- Fuse (3A)

Operating Temperature

- 0°C to 50°C (advised to use the machine under normal temperature)

Test Pieces (Sphere Type)

Fe		②mm										
Fe 100.0	Fe 10.0	Fe 1.0	Fe 0.8	Fe 0.6	Fe 0.5	Fe 0.4	Fe 0.3	Fe 0.2	Fe 0.1	Fe 0.05	Fe 0.02	Fe 0.01
3.5	4.0	4.5	5.0	6.0	7.0	8.0	9.0	10				
Non-Fe		②mm										
Non-Fe 100.0	Non-Fe 10.0	Non-Fe 1.0	Non-Fe 0.8	Non-Fe 0.6	Non-Fe 0.5	Non-Fe 0.4	Non-Fe 0.3	Non-Fe 0.2	Non-Fe 0.1	Non-Fe 0.05	Non-Fe 0.02	Non-Fe 0.01
4.0	4.5	5.0	6.0	7.0	8.0	9.0	10					
SUS304		②mm										
SUS304 100.0	SUS304 10.0	SUS304 1.0	SUS304 0.8	SUS304 0.6	SUS304 0.5	SUS304 0.4	SUS304 0.3	SUS304 0.2	SUS304 0.1	SUS304 0.05	SUS304 0.02	SUS304 0.01
4.0	4.5	5.0	6.0	7.0	8.0	9.0	10					

* Certificate of Conformity for Test Pieces is available upon request

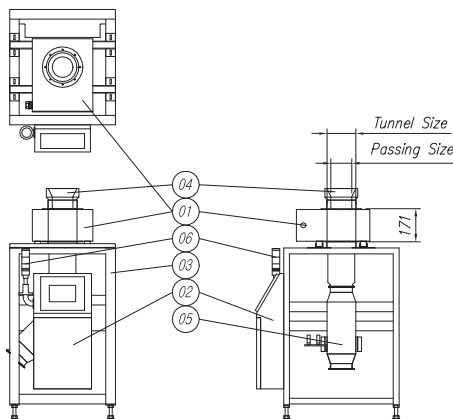

No	Description	Material
1	Metal Detector	SUS304
2	Controller Box	SUS304
3	Frame	SUS304
4	Pipe	PE
5	Rejector Diverter	SUS304
6	Tower Lamp	.

Tunnel Size (mm)	60	80	100	120	150	200	250
Passing Size (mm)	30	50	70	90	120	170	220

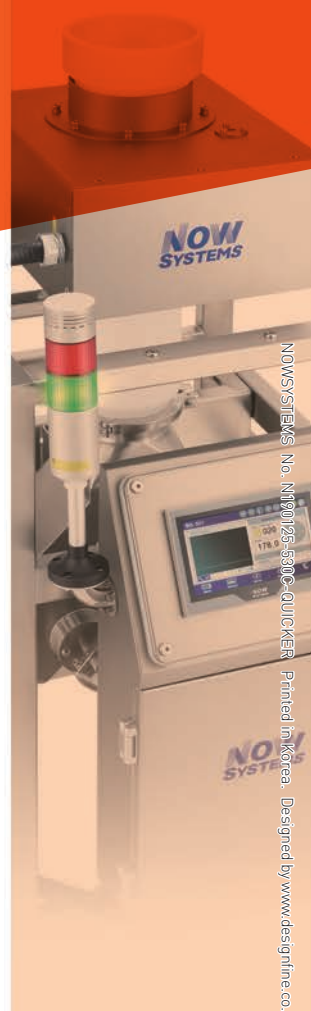

Application

